



TT7/TR7 DIGITAL PROPORTIONAL REMOTE CONTROLLER

Features

Transmitter : TT7

- Operating voltage : 2.4V to 5.5V.
- RC oscillator.
- 3 input control pins for CH1, CH2, CH3 (CH1 & CH2 with VR control, CH3 with ON/OFF control).
- Typical oscillator frequency : 80KHz.

Receiver : TR7

- Operating voltage : 2.4V to 5.5V.
- Proportional channel:
- CH1 as forward and backward motor control with 8 steps, 7 steps controlling motor speed and 1 step controlling dead band.
- CH2 as smooth and accurate steering providing 32 steps to control angles in left and right.
- Auto Power Cut-off pin provided to monitor forward and backward motor and whether there is excess operating current. The cut-off voltage can be control by “cutth” pin.
- Adjustable (by mask option) signal detect threshold voltage to efface noise acrdss.
- Typical oscillator frequency : 80KHz.

General Description

TT7/TR7 are a pair of IC designed for digital proportional radio control system, where TT7 is the transmitter and TR7 is the receiver. The TT7/TR7 provide a 3-channel remote controller for digital remote controlled car application.

TT7/TR7 have 3 channels, CH1,CH2 and CH3. CH1 is a digitized control handling Forward and Backward motions, where 7 steps controlling motor forward speed, and another 7 steps for backward speed. CH2 is a digitized proportional control used to steer servo-motor consisted of 32 steps to drive angles in left and right directions. CH3 is the ON/OFF control.

In addition, TR7 also provides Auto Power-Off function to detect excessive current of Forward/Backward motor under special conditions according to Toy Safety Requirements.

Pin Assignment

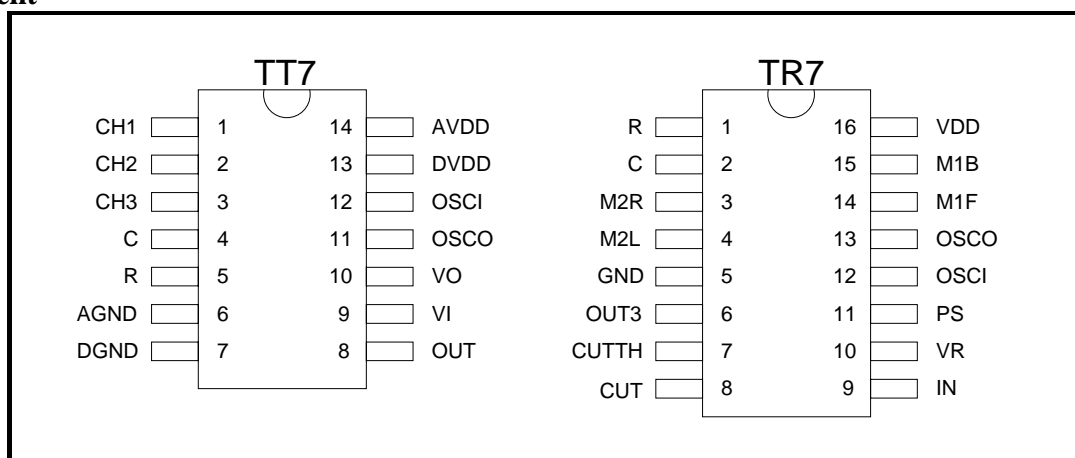

* All specs and applications shown above subject to change without prior notice.
(以上電路及規格僅供參考,本公司得逕行修正)

**Absolute Maximum Ratings**

DC Supply Voltage	0.3V to 5.0V
Input/Output Voltage	GND -0.2V to VDD + 0.2V
Operating Temperature	-10 to 60
Storage Temperature	-25 to 125

Pin Description**TT7**

No.	Name	Description
1	CH1	Input pin for Channel 1 control
2	CH2	Input pin for Channel 2 control
3	CH3	Input pin for Channel 3 control
4	C	Capacitor input for setting encoder pulse width
5	R	Resister input pin for setting encoder pulse width
6	AGND	Analog negative power supply
7	DGND	Digital negative power supply
8	OUT	Signal output pin for transmitting encoded data
9	VI	Inverter input pin
10	VO	Inverter output pin
11	OSCO	Oscillator output pin
12	OSCI	Oscillator input pin
13	DVDD	Digital positive power supply
14	AVDD	Digital positive power supply

TR7

No.	Name	Description
1	R	Resister input for settint reference pulse width
2	C	Capacitor input pin for setting reference pulse width
3	M2R	Channel 2 right motor control pin
4	M2L	Channel 2 left motor control pin
5	GND	Negative power supply
6	OUT3	Channel 3 output control pin (active high)
7	CUTTH	Input pin, adjusting cut-off voltage
8	CUT	Input pin, detecting motor cut-off
9	IN	Encoded signal input pin
10	VR	Sever motor feedback signal input pin
11	PS	Input pin for setting reference pulse follow encoded data speed
12	OSCI	Oscillator input pin
13	OSCO	Oscillator output pin
14	M1F	Channel 1 forward motor control pin
15	M1B	Channel 1 backward motor control pin
16	VDD	Positive power supply

* All specs and applications shown above subject to change without prior notice.

(以上電路及規格僅供參考,本公司得逕行修正)



Electrical Characteristics

TT7

Parameter	Symbol	Min.	Typ.	Max.	Condition
Operating Voltage	V _{DD}	2.4V	4.5V	5.5V	
Operating Current	I _{DD}	-	-	0.5mA	CH1,2 pull high 200KΩ OUT pin unload
Out Driving Current	I _{DRIVER}	5mA	-	-	V _{OH} = 0.7V
Oscillator Frequency Deviation Per Lot	ΔF/F	-	-	±15%	

TR7

Parameter	Symbol	Min.	Typ.	Max.	Test Condition
Operating Voltage	V _{DD}	2.4V	4.5V	5.5V	
Operating Current	I _{DD}	-	-	1.5mA	Unload
Output Driving Current	I _{drive}	10mA	-	-	V _{OH} = 0.7V
OUT3 Driving Current	I _{OUT3}	5mA	-	-	V _{OH} = 2.4V
Oscillator Frequency Deviation Per Lot	ΔF/F	-	-	±15%	

Signal Format

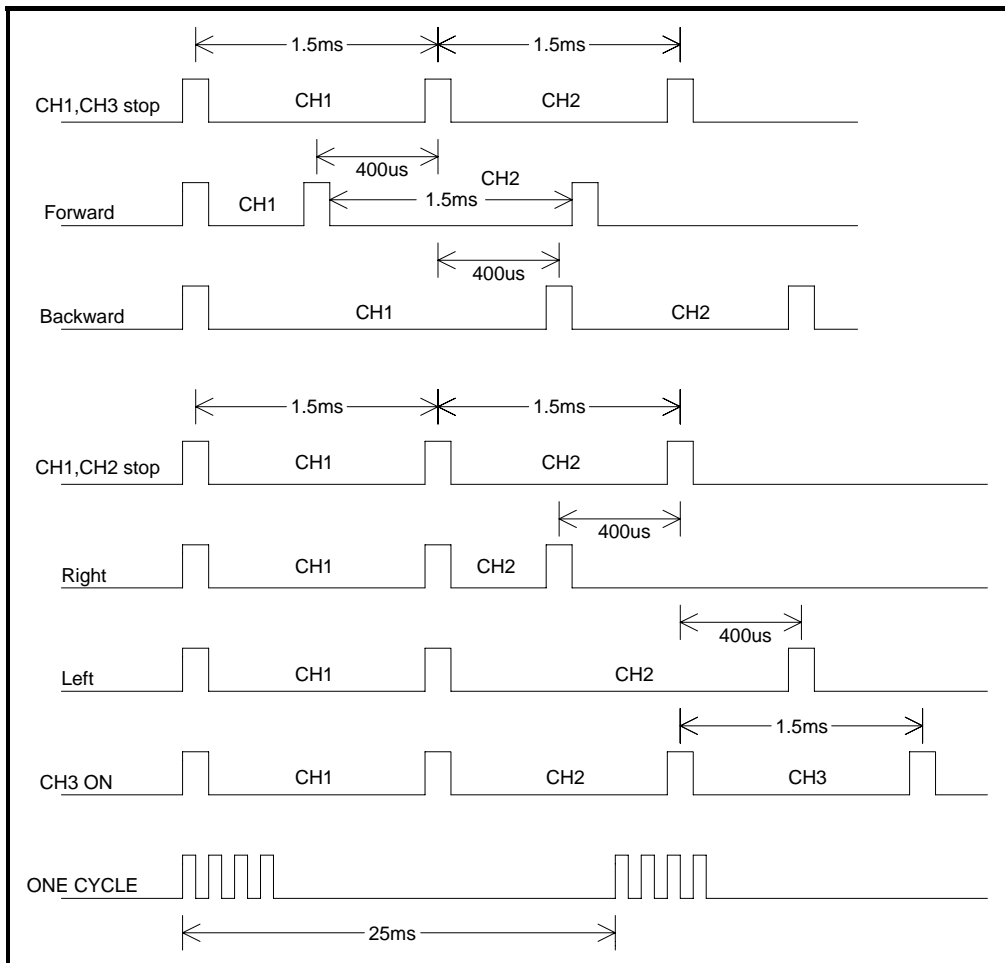

* All specs and applications shown above subject to change without prior notice.
(以上電路及規格僅供參考,本公司得逕行修正)



Dead band of forward/backward

The forward/backward functions use 7 steps to drive the speed of motor, and 1 step to make dead band. Each step is 3.125ms.

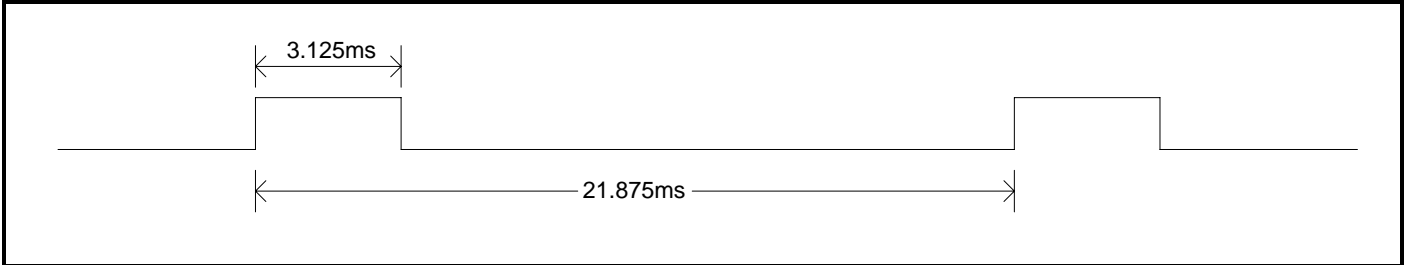

Application Circuit

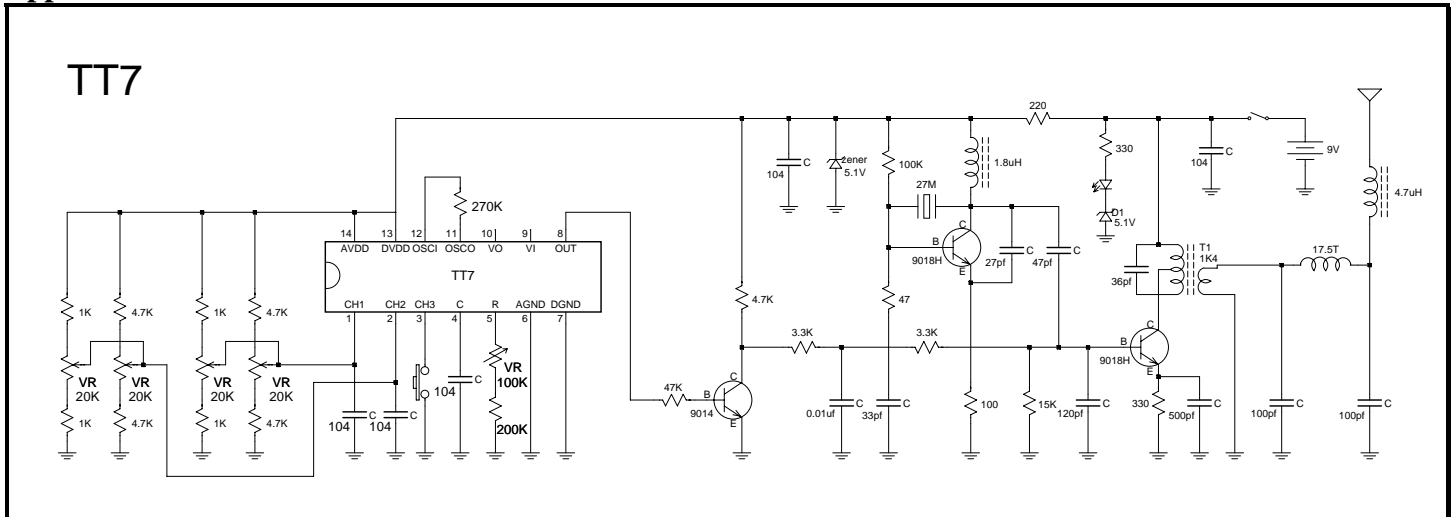

* All specs and applications shown above subject to change without prior notice.
(以上電路及規格僅供參考,本公司得逕行修正)



TR7

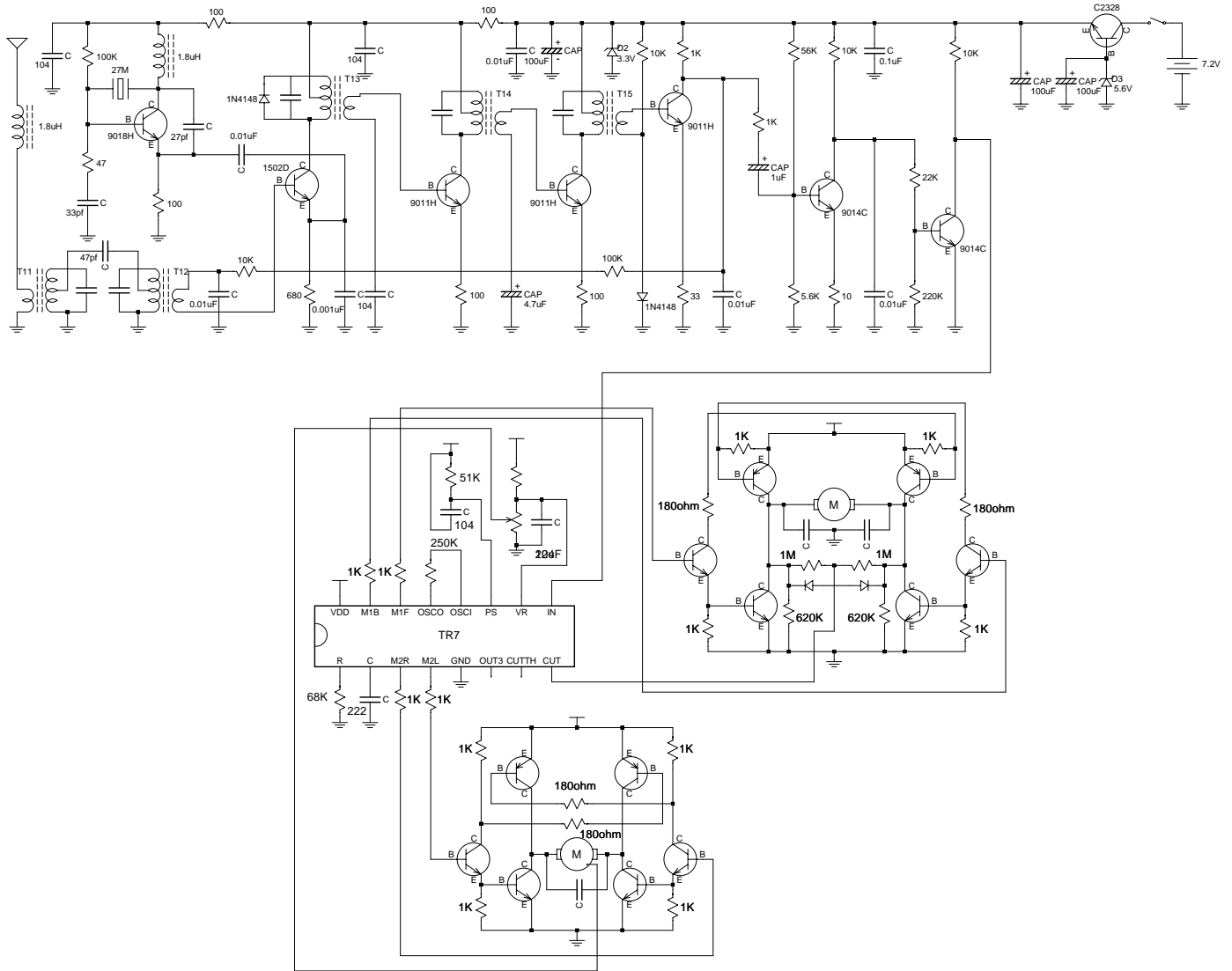

* All specs and applications shown above subject to change without prior notice.
(以上電路及規格僅供參考,本公司得逕行修正)